

<b>Request for BIDS</b>	 <b>MARSHALL UNIVERSITY</b>	<b>Marshall University Office of Purchasing One John Marshall Drive Huntington, WV 25755-4100</b> Direct all inquiries regarding this order to: (304) 696-2821	Bid # <small>R1802127 Page 1</small>  <b>R1802127</b>
-------------------------	---	---	---

<b>Vendor:</b>	<b>For information call:</b>
<b>Phone:</b>	<b>Purchasing Agent: Amanda Dailey</b> <a href="mailto:daileya@marshall.edu">daileya@marshall.edu</a> and <a href="mailto:purchasing@marshall.edu">purchasing@marshall.edu</a>
<b>FEIN/SSN:</b>	<b>Fax:</b>
	<b>Phone: (304)696-2821</b>

Sealed requests for bids furnishing commodities and/or services described below will be received by the Institution. TO RECEIVE CONSIDERATION FOR AWARD, UN LESS OTHERWISE NOTED, THE BID WILL BE SUBMITTED IN BONFIRE ON OR BEFORE THE DATE AND TIME SHOWN FOR THE BID OPENING. The Institution reserves the right to accept or reject bids separately or as a whole, to reject any or all bids, to waive informalities or irregularities and to contract as the best interests of the Institution may require. BIDS ARE SUBJECT TO THE GENERAL TERMS AND CONDITIONS AS SET FORTH HEREIN

<b>DATE</b> 4/16/18		<b>Department Requisition No.</b>	<b>BIDS OPEN:</b> <b>April 26, 2018</b> <b>3:00 pm</b>	<b>BIDDER MUST ENTER DELIVERY DATE FOR EACH ITEM BID</b>
------------------------	--	-----------------------------------	--	--

Item #	Quantity	Description	Unit Price	Extended Price
		<b>INVITATION TO BID</b>  Marshall University will accept bids for the following services until 3:00 PM on April 26, 2018. At that time, <b>Bonfire Submissions</b> Will be opened, recorded, and read aloud in Room 125, Old Main Building, and Office of Purchasing.  Washers & Dryers for Housing and Residence Life. As specified or equivalent. Bidders must provide specification with alternate bids.  All bidding documents must be submitted in BONFIRE In accordance with the bidding documents issued by Marshall University. <b><a href="https://marshall.bonfirehub.com/opportunities/7874">https://marshall.bonfirehub.com/opportunities/7874</a></b>		
<b>Total</b>				

To the Purchasing Department,  
 In compliance with the above, the undersigned offers and agrees, if this offer is accepted within \_\_\_\_\_ calendar days (30 calendar days unless a different period is inserted by the purchaser) from the bid open date, specified above, to furnish any or all items upon which prices are offered, at the price set opposite each item, delivered at the designated point(s), within the time specified.

Bidder guarantees shipment from _____	Bidder's name Vendor _____
within _____ days	Signed By _____
FOB _____ After receipt of order at address shown	Typed Name _____
Terms _____	Title _____
	Street Address _____
	City/State/Zip _____
	Date _____ Phone _____
	Fein _____

**2018 BIDS WASHER / DRYER**

Marshall University will be accepting Bids for the equipment listed below. All equipment will be delivered to Marshall University on Date given by Marshall University.  
Vendor will provide a local authorized dealer for Warranty parts.  
See attached Documents.

- 1- SPEED QUEEN STACK WASHER / DRYER  
ELECTRONIC HOME STYLE / MOD – LTEE5ASP175TW01 / 240 V  
TOTAL – (4)
  
- 2- SPEED QUEEN STACK DRYER  
ELECTRONIC HOMESTYLE / MOD – LSEE5AGW173TW01 / 240 V  
TOTAL – (14)
  
- 3- SPEED QUEEN FRONT LOAD WASHER  
ELECTRONIC HOMESTYLE ADA COMPLIANT / MOD – LFNE5BSP115TW01  
TOTAL (10)
  
- 4- SPEED QUEEN SINGLE DRYER  
ELECTRONIC HOMESTYLE ADA COMPLIANT / MOD – LDEE5BGS173TW01 /240 V  
TOTAL (6)
  
- 5- SPEED QUEEN TOP LOAD WASHER  
MECHANICAL HOMESTYLE / LWN432SP115TW01  
TOTAL – (63)
  
- 6- SPEED QUEEN SINGLE DRYER  
MECHANICAL HOMESTYLE / MOD – LDE30RGS173TW01 / 240 V  
TOTAL (47)
  
- 7- 3- PRONG DRYER CORD  
TOTAL (54)
  
- 8 - 4- PRONG DRYER CORD  
TOTAL (30)
  
- 9 - BRADED WASHER HOSE / HOT  
TOTAL HOT / (78)
  
- 10 - BRADED WASHER HOSE / COLD  
TOTAL COLD / (78)
  
- 11 - ALUMINUM DRYER VENT HOSE  
TOTAL - (80)

## FRONT CONTROL LFNE5BSP1 15TW01, LFNE5BJP1 15TW01 FRONT LOAD WASHER

### Front Load Washers

Designed to be everything you never thought a washing machine could be, the revolutionary Speed Queen® front load washers feature an unprecedented amount of cutting-edge innovations to help you improve performance and minimize costs.

- Revolutionary balancing technology redistributes unbalanced load for uninterrupted wash cycles.
- Increase spin speed extracts 440 G-Force to maximize moisture removal and lower drying times.
- 20% increase in capacity with improved water usage to decrease operating costs.
- Redesigned 4-compartment soap dispenser for simplified use and cleaning.



### Electronic Homestyle

Speed Queen® washers with Electronic Homestyle controls are designed for durability and are easy to operate with intuitive selection buttons and cycle status indicator lights. This control option features a time-remaining display, six preset cycle buttons, cycle adjustability for temperature, load size and soil levels along with additional cycle enhancer options for a pre-wash or second rinse cycle.

# SPECIFICATIONS

## FRONT LOAD WASHER

MODEL	<b>LFNE5BSP115TW01</b> <b>LFNE5BJP115TW01</b>	
CONTROL OPTION	Electronic Homestyle	
CONTROL LOCATION	Front	
CAPACITY - lb (kg)	21.5 (10)	
CYLINDER VOLUME - cu. ft. (liters)	3.42 (96.8)	
OVERALL WIDTH - in (mm)	26.875 (683)	
OVERALL DEPTH - in (mm)	27.73 (704)	
OVERALL HEIGHT - in (mm)	40.42 (1027)	
SPIN SPEED G-FORCE -RPM	440 (1200)	
MOTOR POWER CONSUMPTION - hp (kw)	0.9 (0.67)	
VARIABLE SPEED INDUCTION		
WATER CONSUMPTION PER CYCLE -g (l)	13.68 (51.8)	
IWF (Water Factor)	4.0 (0.53)	
IMEF (Modified Energy Factor)	2.20 (62.3)	
AVAILABLE WATER TEMPERATURES	3	
*AVAILABLE CYCLES	Heavy Duty, Normal Eco, Perm Press, Delicate, Rinse & Spin, Spin Only	
WATER PRESSURE -PSI (Bar)	20-120 (1.4/8.3)	
CYCLE INDICATOR LIGHTS	Yes	
CYLINDER FINISH	Stainless Steel	
AVAILABLE COLORS	White	
DOOR TYPE (Solid/Window)	Window	
AVAILABLE ELECTRICAL REQUIREMENTS - Voltage/Hz/Ph - Circuit Amperage	120/60/1 - 15	
SHIPPING DIMENSIONS APPROX. - in (mm)	Width	30 (762)
	Depth	34 (864)
	Height	44.5 (1130)
NET WEIGHT - lb (kg)	260 (118)	
SHIPPING WEIGHT - lb (kg)	270 (122)	
AGENCY APPROVALS	cULus	

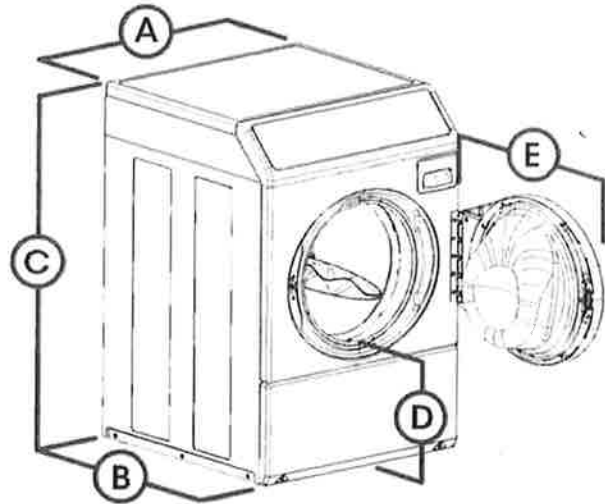

A.	OVERALL WIDTH - in (mm)	26.875 (683)
B.	OVERALL DEPTH - in (mm)	27.73 (704)
C.	OVERALL HEIGHT - in (mm)	40.42 (1027)
D.	FLOOR TO DOOR OPENING - in (mm)	14.6 (371)
E.	DOOR SWING - in (mm)	24.06 (611)

ADA Compliant

Note: Not all options are available for all models. Refer to the price list for the available models and options.

\* Information shown applies to highest end control available.

For the most accurate information, the installation guide should be used for all design and construction purposes. Due to continuous product improvements, design and specifications subject to change without notice. The quality management system of Alliance Laundry Systems' Ripon facility has been registered to ISO 9001:2008.

REAR CONTROL LDEE7RWS173TW01, LDGE7RWS113TW01, LDE30RGS173TW01, LDE30RGS153TW01, LDG30RGS113TW01, SDEMNRGS173TW01, SDEMNRGS153TW01, SDGMNRGS113TW01

## SINGLE DRYER

### Single Dryers

With an easy-to-clean large lint compartment and a reversible door to accommodate your laundry design, Speed Queen® single dryers are designed to suit your laundry's specific needs. The 2.06 sq. ft. door opening is the largest in the industry, providing easy loading and unloading.

- Durable galvanized steel cylinder with an extra-large 7 cu. ft. of volume.
- Efficient dryer heating with 22,500 or 25,000 Btu (gas models) and 5350 or 4750 Watts (electric models).



#### Electronic Homestyle

Speed Queen® dryers with Electronic Homestyle controls are designed for durability and are easy to operate with intuitive selection buttons and cycle status indicator lights. This control option features a time-remaining display, six preset cycle buttons, cycle adjustability for temperature and load size.

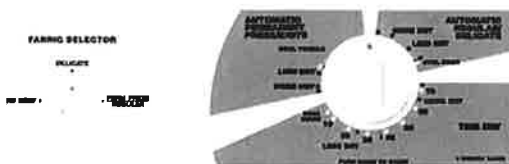

#### Mechanical Homestyle

Speed Queen® dryers with Mechanical Homestyle controls are designed for durability and are easy to operate with a multi-cycle timer knob and automatic dry cycles.

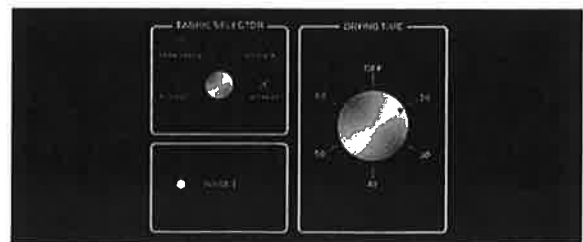

#### E-Mech

The E-Mech control features a straightforward design that offers users simple temperature and fabric selections. Cue lights keep them aware of whether the machine is in use, as well as the current cycle status. Available on rear control single dryers.

# SPECIFICATIONS

## SINGLE DRYER

MODEL/ CONTROL OPTION	Electronic Homestyle	<b>LDEE7RWS173TW01, LDGE7RWS113TW01</b>
	Mechanical Homestyle	<b>LDE30RGS173TW01, LDE30RGS153TW01, LDG30RGS113TW01</b>
	E-Mech	<b>SDEMNRGS173TW01, SDEMNRGS153TW01, SDGMNRGS113TW01</b>
CONTROL LOCATION	Rear	
CAPACITY - lb (kg)	18 (8.2)	
CYLINDER VOLUME - cu. ft. (liters)	7.0 (198)	
OVERALL WIDTH - in (mm)	26.875 (683)	
OVERALL DEPTH - in (mm)	28 (711)	
OVERALL HEIGHT - in (mm)	43 (1092)	
MOTOR POWER CONSUMPTION - hp (kw)	0.33 (0.25)	
AVAILABLE HEAT SOURCES	Gas or Electric	
*AVAILABLE HEATING ELEMENT (Electric W)	5350 @ 240V	
GAS INLET CONNECTION - in (mm)	3/8 (9.5)	
*GAS CONSUMPTION - BTU/Hr	22,500	
EXHAUST OUTLET DIA. - in (mm)	4 (102)	
EXHAUST AIRFLOW - cfm (liters/sec)	220 (105)	
*AVAILABLE CYCLES	Regular, Perm Press, Delicate, Time Dry, Quick Dry, Fluff Up	
*CYCLE INDICATOR LIGHTS	Yes	
CYLINDER FINISH	Galvanized or White	
AVAILABLE COLORS	White	
DOOR TYPE (Solid/Window)	Solid	
AVAILABLE ELECTRICAL REQUIREMENTS - Voltage/Hz/Ph - Circuit Amperage	Electric	120/240/60/1 -30 120/208/60/1 -30
	Gas	120/60/1 - 15
SHIPPING DIMENSIONS APPROX. - in (mm)	Width	29.5 (749)
	Depth	30.5 (775)
	Height	45 (1143)
NET WEIGHT - lb (kg)	Electric	126 (57)
	Gas	130 (59)
SHIPPING WEIGHT - lb (kg)	Electric	136 (62)
	Gas	140 (64)
AGENCY APPROVALS	Electric	cULus
	Gas	cCSAus

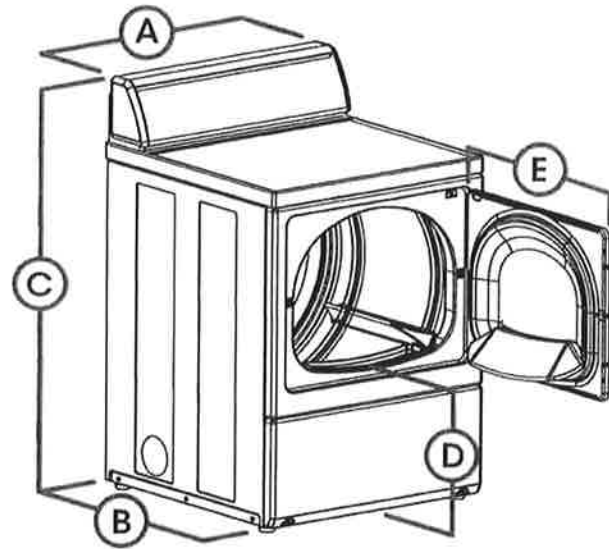

A.	OVERALL WIDTH - in (mm)	26.875 (683)
B.	OVERALL DEPTH - in (mm)	28 (711)
C.	OVERALL HEIGHT - in (mm)	43 (1092)
D.	FLOOR TO DOOR OPENING - in (mm)	15.44 (392)
E.	DOOR SWING - in (mm)	23.5 (597)

ADA Compliant

Note: Not all options are available for all models. Refer to the price list for the available models and options.

\* Information shown applies to highest end control available.

For the most accurate information, the installation guide should be used for all design and construction purposes. Due to continuous product improvements, design and specifications subject to change without notice. The quality management system of Alliance Laundry Systems' Ripon facility has been registered to ISO 9001:2008.

## FRONT CONTROL LDEE5BGS173TW01, LDEE5BGS153TW01, LDGE5BGS113TW01 SINGLE DRYER

### Single Dryers

With an easy-to-clean large lint compartment and a reversible door to accommodate your laundry design, Speed Queen® single dryers are designed to suit your laundry's specific needs. The 2.06 sq. ft. door opening is the largest in the industry, providing easy loading and unloading.

- Durable galvanized steel cylinder with an extra-large 7 cu. ft. of volume.
- Efficient dryer heating with 22,500 Btu (gas models) and 5350 Watts (electric models).



### Electronic Homestyle

Speed Queen® dryers with Electronic Homestyle controls are designed for durability and are easy to operate with intuitive selection buttons and cycle status indicator lights. This control option features a time-remaining display, six preset cycle buttons, cycle adjustability for temperature and load size.

# SPECIFICATIONS

## SINGLE DRYER

MODEL	<b>LDEE5BGS173TW01, LDEE5BGS153TW01, LDGE5BGS113TW01</b>	
CONTROL OPTION	Electronic Homestyle	
CONTROL LOCATION	Front	
CAPACITY - lb (kg)	18 (8.2)	
CYLINDER VOLUME - cu. ft. (liters)	7.0 (198)	
OVERALL WIDTH - in (mm)	26.875 (683)	
OVERALL DEPTH - in (mm)	28 (711)	
OVERALL HEIGHT - in (mm)	40.42 (1027)	
MOTOR POWER CONSUMPTION - hp (kw)	0.33 (0.25)	
AVAILABLE HEAT SOURCES	Gas or Electric	
AVAILABLE HEATING ELEMENT (Electric W)	5350 @ 240V	
GAS INLET CONNECTION - in (mm)	3/8 (9.5)	
GAS CONSUMPTION - BTU/Hr	22,500	
EXHAUST OUTLET DIA. - in (mm)	4 (102)	
EXHAUST AIRFLOW - cfm (liters/sec)	220 (105)	
*AVAILABLE CYCLES	Regular, Perm Press, Delicate, Time Dry, Quick Dry, Fluff Up	
CYCLE INDICATOR LIGHTS	Yes	
CYLINDER FINISH	Galvanized	
AVAILABLE COLORS	<b>White</b>	
DOOR TYPE (Solid/Window)	Solid	
AVAILABLE ELECTRICAL REQUIREMENTS - Voltage/Hz/Ph - Circuit Amperage	Electric	120/240/60/1 -30
	Gas	120/60/1 - 15
SHIPPING DIMENSIONS APPROX. - in (mm)	Width	29.5 (749)
	Depth	30.5 (775)
	Height	45 (1143)
NET WEIGHT - lb (kg)	Electric	126 (57)
	Gas	130 (59)
SHIPPING WEIGHT - lb (kg)	Electric	136 (62)
	Gas	140 (64)
AGENCY APPROVALS	Electric	cULus
	Gas	cCSAus

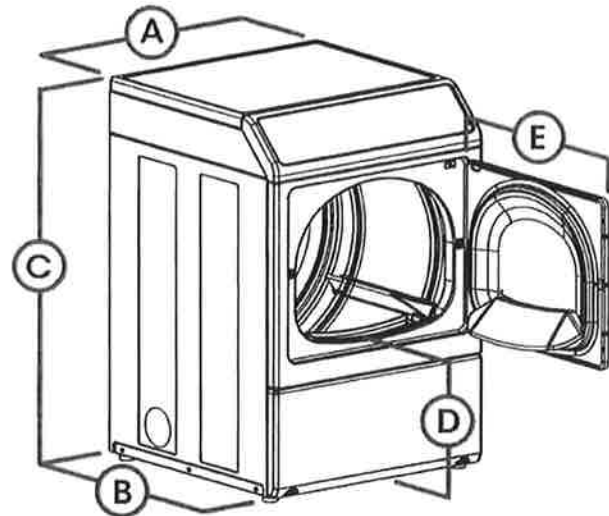

A.	OVERALL WIDTH - in (mm)	26.875 (683)
B.	OVERALL DEPTH - in (mm)	28 (711)
C.	OVERALL HEIGHT - in (mm)	40.42 (1027)
D.	FLOOR TO DOOR OPENING - in (mm)	15.44 (392)
E.	DOOR SWING - in (mm)	23.5 (597)

ADA Compliant

Note: Not all options are available for all models. Refer to the price list for the available models and options.

\* Information shown applies to highest end control available.

For the most accurate information, the installation guide should be used for all design and construction purposes. Due to continuous product improvements, design and specifications subject to change without notice. The quality management system of Alliance Laundry Systems' Ripon facility has been registered to ISO 9001:2008.



FRONT CONTROL LSEE5AGS173TW01, LSEE5AGS153TW01, LSEE5AGW173TW01,  
LSEE5AGW153TW01, LSGE5AGS113TW01, LSGE5AGW113TW01, SSEMNAGS173TW01,  
SSEMNAGS153TW01, SSGMNAGS113TW01

## STACK DRYER

### Stack Dryers

Get twice the drying capacity in the compact floor space of a single dryer with Speed Queen® stack dryers. Combined with extra capacity for large loads, the stack dryer gets the maximum amount of work done without breaking the bank – or your laundry design.

- Extra large capacity for large loads.
- 2.06 sq. ft. door opening is the largest in the industry, providing easy loading and unloading.
- Efficient dryer heating with 22,500 Btu (gas models) and 5350 Watts (electric models)

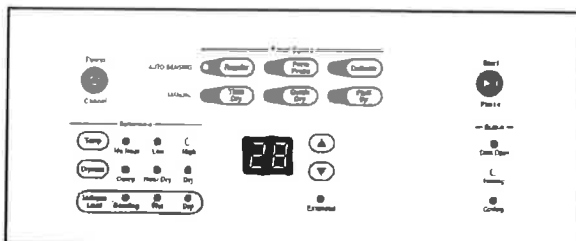

#### Electronic Homestyle

Speed Queen® dryers with Electronic Homestyle controls are designed for durability and are easy to operate with intuitive selection buttons and cycle status indicator lights. This control option features a time-remaining display, six preset cycle buttons, cycle adjustability for temperature and load size.



#### E-Mech

The E-Mech control features a straightforward design that offers users simple water temperature and fabric selections. Cue Lights keep them aware of whether the machine is in use, as well as the current cycle status.

# SPECIFICATIONS

## STACK DRYER

MODEL/ CONTROL OPTION	Electronic Homestyle	<b>LSEE5AGS173TW01, LSEE5AGS153TW01, LSEE5AGW173TW01, LSEE5AGW153TW01, LSGE5AGS113TW01, LSGE5AGW113TW01</b>
	E-Mech	<b>SSEMNAGS173TW01, SSEMNAGS153TW01, SSGMNAGS113TW01</b>
CONTROL LOCATION	Front	
CAPACITY - lb (kg)	18 (8.2)	
CYLINDER VOLUME - cu. ft. (liters)	7.0 (198)	
OVERALL WIDTH - in (mm)	26.875 (683)	
OVERALL DEPTH - in (mm)	28 (711)	
OVERALL HEIGHT - in (mm)	78.17 (1986)	
MOTOR POWER CONSUMPTION - hp (kw)	0.33 (0.25)	
AVAILABLE HEAT SOURCES	Gas or Electric	
AVAILABLE HEATING ELEMENT (Electric W)	5350 @ 240V	
GAS INLET CONNECTION - in (mm)	3/8 (9.5)	
GAS CONSUMPTION - BTU/Hr	22,500	
EXHAUST OUTLET DIA. - in (mm)	4 (102)	
EXHAUST AIRFLOW - cfm (liters/sec)	220 (105)	
*AVAILABLE CYCLES	Regular, Perm Press, Delicate, Time Dry, Quick Dry, Fluff Up	
CYCLE INDICATOR LIGHTS	Yes	
CYLINDER FINISH	Galvanized	
AVAILABLE COLORS	White	
DOOR TYPE (Solid/Window)	Solid or Window	
AVAILABLE ELECTRICAL REQUIREMENTS - Voltage/Hz/Ph - Circuit Amperage	Electric	120/240/60/1 -30 120/208/60/1
	Gas	120/60/1 - 15
SHIPPING DIMENSIONS APPROX. - in (mm)	Width	30 (762)
	Depth	33 (838)
	Height	80 (2032)
NET WEIGHT - lb (kg)	Electric	262 (119)
	Gas	270 (122)
SHIPPING WEIGHT - lb (kg)	Electric	272 (123)
	Gas	280 (127)
AGENCY APPROVALS	Electric	cULus
	Gas	cCSAus

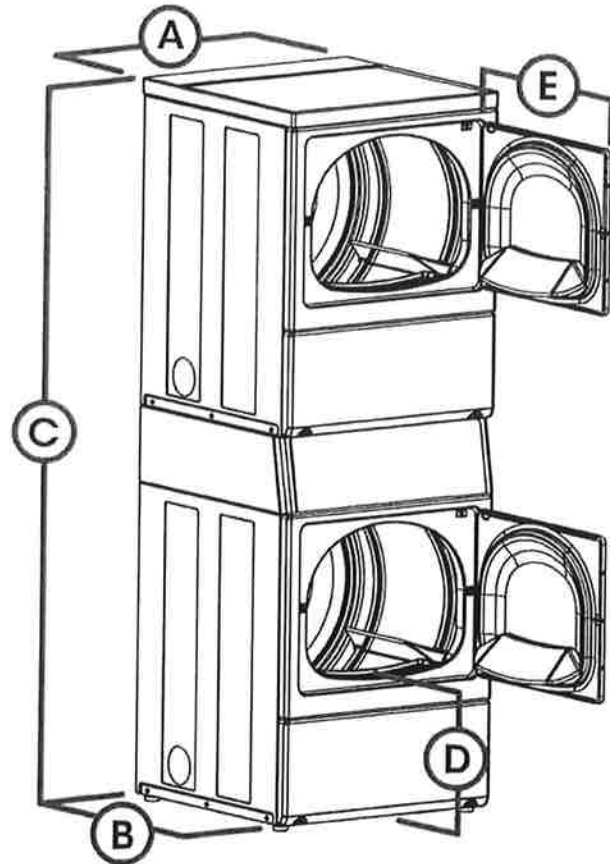

A.	OVERALL WIDTH - in (mm)	26.875 (683)
B.	OVERALL DEPTH - in (mm)	28 (711)
C.	OVERALL HEIGHT - in (mm)	78.17 (1986)
D.	FLOOR TO DOOR OPENING - in (mm)	15.44 (392)
E.	DOOR SWING - in (mm)	23.5 (597)

ADA Compliant - Lower Unit

Note: Not all options are available for all models. Refer to the price list for the available models and options.

\* Information shown applies to highest end control available.

For the most accurate information, the installation guide should be used for all design and construction purposes. Due to continuous product improvements, design and specifications subject to change without notice. The quality management system of Alliance Laundry Systems' Ripon facility has been registered to ISO 9001:2008.

## FRONT CONTROL LTEE5ASP175TW01, LTEE5ASP155TW01, LTGE5ASP115TW01 STACK WASHER/DRYER

### Stack Washer/Dryers

Our stack washer/dryers are designed as vertical combinations that provide all of the power of Speed Queen® washers and dryers while occupying only half of the floor space of a conventional washer and dryer setup. Plus, these stacked units allow you to utilize the same connections and hook-ups required be a standard washer and dryer, so you won't have to make changes to your installation.

- ENERGY STAR® Qualified to use less energy, save money and help protect the environment.
- Water use is trimmed to 13.9 gallons per cycle to reduce operating costs.

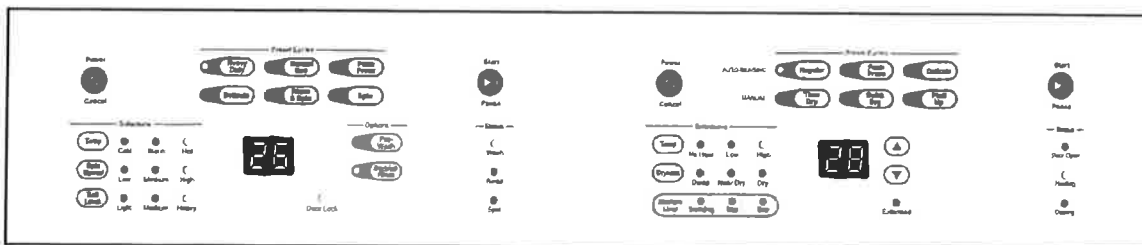

Washer Control

Dryer Control

### Electronic Homestyle

Speed Queen® washers and dryers with Electronic Homestyle controls are designed for durability and are easy to operate with intuitive selection buttons and cycle status indicator lights. This control option features a time-remaining display, six preset cycle buttons, cycle adjustability for temperature and load size, soils levels along with additional cycle enhancer options for a pre-wash or second rinse cycle.

## SPECIFICATIONS

## STACK WASHER/DRYER

MODEL	LTEE5ASP175TW01, LTEE5ASP155TW01, LTGE5ASP115TW01	
CONTROL OPTION	Electronic Homestyle	
CONTROL LOCATION	Front	
CAPACITY - lb (kg)	Washer	21.5 (10)
	Dryer	18 (8.2)
CYLINDER VOLUME - cu. ft. (liters)	Washer	3.42 (96.8)
	Dryer	7.0 (198)
OVERALL WIDTH - in (mm)	26.875 (683)	
OVERALL DEPTH - in (mm)	27.73 (704)	
OVERALL HEIGHT - in (mm)	78.5 (1994)	
SPIN SPEED G-FORCE -RPM	440 (1200)	
MOTOR POWER CONSUMPTION - hp (kw)	Washer	0.9 (0.67) Variable Speed
	Dryer	0.33 (0.25)
WATER CONSUMPTION PER CYCLE -g (l)	13.68 (51.8)	
IWF (Water Factor)	4.0 (0.53)	
IMEF (Modified Energy Factor)	2.20 (62.3)	
AVAILABLE HEAT SOURCES	Gas or Electric	
AVAILABLE HEATING ELEMENT (Electric W)	5350 @ 240V	
GAS INLET CONNECTION - in (mm)	3/8 (9.5)	
GAS CONSUMPTION - BTU/Hr	22,500	
EXHAUST OUTLET DIA. - in (mm)	4 (102)	
EXHAUST AIRFLOW - cfm (liters/sec)	220 (105)	
AVAILABLE WATER TEMPERATURES	3	
*AVAILABLE CYCLES	Washer	Heavy Duty, Normal Eco, Perm Press, Delicate, Rinse & Spin, Spin Only
	Dryer	Regular, Perm Press, Delicate, Time Dry, Quick Dry, Fluff Up
WATER PRESSURE -PSI (Bar)	20-120 (1.4/8.3)	
CYCLE INDICATOR LIGHTS	Yes	
CYLINDER FINISH	Washer	Stainless Steel
	Dryer	Galvanized
AVAILABLE COLORS	White	
DOOR TYPE (Solid/Window)	Window	
AVAILABLE ELECTRICAL REQUIREMENTS - Voltage/Hz/Ph - Circuit Amperage	Washer	120/60/1 - 15
	Electric	120/240/60/1 -30
	Gas	120/60/1 - 15
SHIPPING DIMENSIONS APPROX. - in (mm)	Width	30 (762)
	Depth	34 (864)
	Height	80 (2032)
NET WEIGHT - lb (kg)	350 (159)	
SHIPPING WEIGHT - lb (kg)	380 (172)	
AGENCY APPROVALS	Electric	cULus
	Gas	cCSAus

ADA Compliant - Lower Unit

Note: Not all options are available for all models. Refer to the price list for the available models and options.

\* Information shown applies to highest end control available.

For the most accurate information, the installation guide should be used for all design and construction purposes. Due to continuous product improvements, design and specifications subject to change without notice. The quality management system of Alliance Laundry Systems' Ripon facility has been registered to ISO 9001:2008.

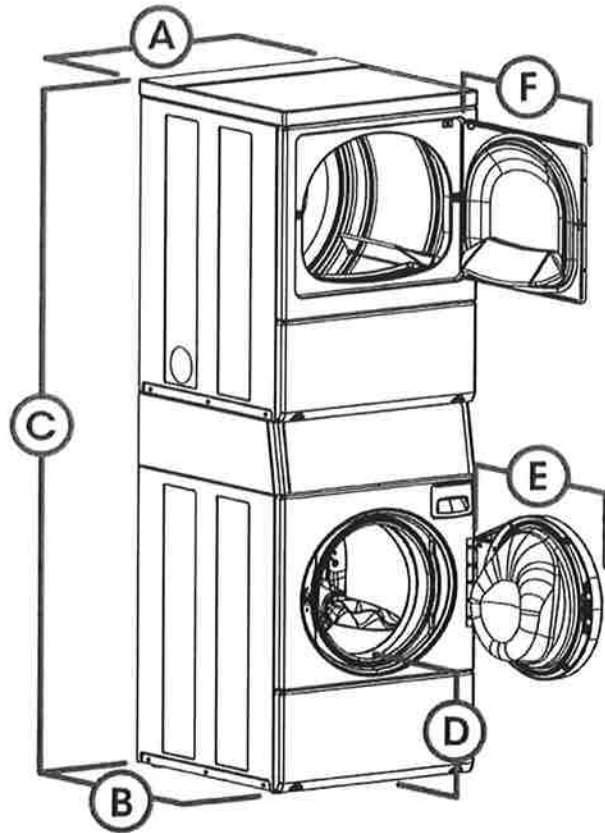

A.	OVERALL WIDTH - in (mm)	26.875 (683)
B.	OVERALL DEPTH - in (mm)	27.73 (704)
C.	OVERALL HEIGHT - in (mm)	78.5 (1994)
D.	FLOOR TO DOOR OPENING - in (mm)	14.5 (368)
E.	WASHER DOOR SWING - in (mm)	24 (610)
F.	DRYER DOOR SWING - in (mm)	23.5 (597)

## REAR CONTROL LWNE22SP115TW01, LWN432SP115TW01, SWNMN2SP115TW01 TOP LOAD WASHER

### Top Load Washers

Our top load washers are constructed from heavy-duty components to ensure an extended life in your laundry operation, including a stainless steel washtub, all-metal transmission and a commercial-grade cabinet finish. Compliant with the current U.S. Department of Energy water and energy standards for commercial washers, your laundry will realize significant savings in water and energy costs.

- Extra large capacity stainless steel tub ensures long-lasting, dependable performance.
- Advanced suspension system eliminates the possibility of an unbalanced load.
- Curved four-vane agitator delivers an industry-best 210° wash stroke that produces unparalleled cleaning results.

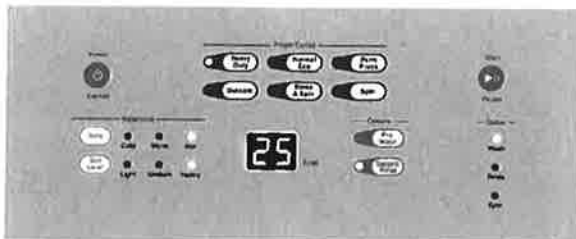

#### Electronic Homestyle

The Electronic Homestyle control is durable and easy to operate with intuitive selection buttons. It features a time-remaining display, six preset cycle buttons, cycle adjustability, along with additional cycle enhancer options for a pre-wash or second rinse cycle.



#### Mechanical Homestyle

Speed Queen® washers with Mechanical Homestyle controls are designed for durability and are easy to operate with a multi-cycle timer knob and extra rinse switch.



#### E-Mech

The E-Mech control features a straightforward design that offers users simple water temperature and fabric selections, and uses cue lights to monitor progress through the wash cycle.

# SPECIFICATIONS

## TOP LOAD WASHER

MODEL/ CONTROL OPTION	Electronic Homestyle (EH)	<b>LWNE22SP115TW01</b>
	Mechanical Homestyle (MH)	<b>LWN432SP115TW01</b>
	E-Mech (EM)	<b>SWNMN2SP115TW01</b>
CONTROL LOCATION	Rear	
CAPACITY - lb (kg)	EH/MH	16 (7.3)
	EM	14 (6.4)
CYLINDER VOLUME - cu. ft. (liters)	EH/MH	3.22 (91.2)
	EM	3.26 (92.3)
OVERALL WIDTH - in (mm)	25.63 (651)	
OVERALL DEPTH - in (mm)	28 (711)	
OVERALL HEIGHT - in (mm)	EH/MH	43 (1092)
	EM	41.25 (1048)
SPIN SPEED G-FORCE -RPM	150 (710)	
MOTOR POWER CONSUMPTION - hp (kw)	0.5 (0.37)	
WATER CONSUMPTION PER CYCLE - g (l)	EH	279 (106)
	MH	279 (106)
	EM	28.07 (106)
IWF (Water Factor)	EH	8.8
	MH	8.8
	EM	8.8
MEF <sub>v</sub> (Modified Energy Factor)	EH/MH	1.35
	EM	1.35
AVAILABLE WATER TEMPERATURES	3	
*AVAILABLE CYCLES	Heavy Duty, Normal Eco, Perm Press, Delicate, Rinse & Spin, Spin Only	
WATER PRESSURE -PSI (Bar)	20-120 (1.4/8.3)	
*CYCLE INDICATOR LIGHTS	Yes	
CYLINDER FINISH	Stainless Steel	
AVAILABLE COLORS	White	
AVAILABLE ELECTRICAL REQUIREMENTS - Voltage/Hz/Ph - Circuit Amperage	120/60/1 -15	
SHIPPING DIMENSIONS APPROX. - in (mm)	Width	28 (711)
	Depth	30 (762)
	Height	45 (1143)
NET WEIGHT - lb (kg)	EH/MH	186 (84)
	EM	206 (93)
SHIPPING WEIGHT - lb (kg)	EH/MH	196 (89)
	EM	218 (99)
AGENCY APPROVALS	cULus	

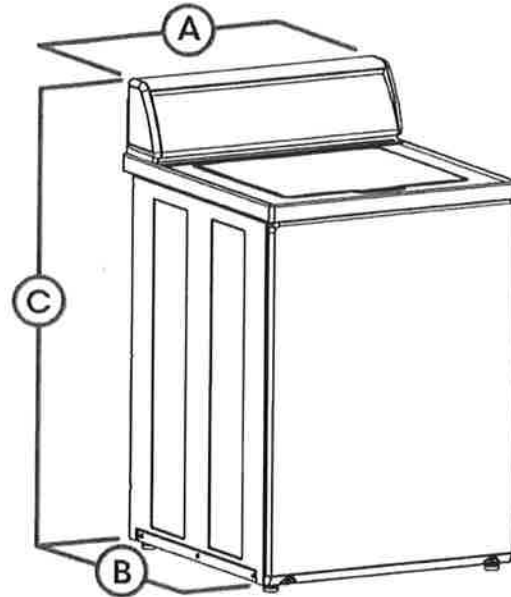

A.	OVERALL WIDTH - in (mm)	25.63 (651)
B.	OVERALL DEPTH - in (mm)	28 (711)
C.	OVERALL HEIGHT - in (mm)	EH/MH 43 (1092)
		EM 41.25 (1048)

ADA Compliant

Note: Not all options are available for all models. Refer to the price list for the available models and options.

\* Information shown applies to highest end control available.

For the most accurate information, the installation guide should be used for all design and construction purposes. Due to continuous product improvements, design and specifications subject to change without notice. The quality management system of Alliance Laundry Systems' Ripon facility has been registered to ISO 9001:2008.

WV-10  
Approved / Revised  
09/15/17

## State of West Virginia

# VENDOR PREFERENCE CERTIFICATE

Certification and application is hereby made for Preference in accordance with **West Virginia Code**, §5A-3-37. (Does not apply to construction contracts). **West Virginia Code**, §5A-3-37, provides an opportunity for qualifying vendors to request (at the time of bid) preference for their residency status. Such preference is an evaluation method only and will be applied only to the cost bid in accordance with the **West Virginia Code**. This certificate for application is to be used to request such preference. The Purchasing Division will make the determination of the Vendor Preference, if applicable.

1.  **Application is made for 2.5% vendor preference for the reason checked:**  
 Bidder is an individual resident vendor and has resided continuously in West Virginia, or bidder is a partnership, association or corporation resident vendor and has maintained its headquarters or principal place of business continuously in West Virginia, for four (4) years immediately preceding the date of this certification; **or**,  
 Bidder is a resident vendor partnership, association, or corporation with at least eighty percent of ownership interest of bidder held by another entity that meets the applicable four year residency requirement; **or**,  
 Bidder is a nonresident vendor which has an affiliate or subsidiary which employs a minimum of one hundred state residents and which has maintained its headquarters or principal place of business within West Virginia continuously for the four (4) years immediately preceding the date of this certification; **or**,
2.  **Application is made for 2.5% vendor preference for the reason checked:**  
 Bidder is a resident vendor who certifies that, during the life of the contract, on average at least 75% of the employees working on the project being bid are residents of West Virginia who have resided in the state continuously for the two years immediately preceding submission of this bid; **or**,
3.  **Application is made for 2.5% vendor preference for the reason checked:**  
 Bidder is a nonresident vendor that employs a minimum of one hundred state residents, or a nonresident vendor which has an affiliate or subsidiary which maintains its headquarters or principal place of business within West Virginia and employs a minimum of one hundred state residents, and for purposes of producing or distributing the commodities or completing the project which is the subject of the bidder's bid and continuously over the entire term of the project, on average at least seventy-five percent of the bidder's employees or the bidder's affiliate's or subsidiary's employees are residents of West Virginia who have resided in the state continuously for the two immediately preceding years and the vendor's bid; **or**,
4.  **Application is made for 5% vendor preference for the reason checked:**  
 Bidder meets either the requirement of both subdivisions (1) and (2) or subdivision (1) and (3) as stated above; **or**,
5.  **Application is made for 3.5% vendor preference who is a veteran for the reason checked:**  
 Bidder is an individual resident vendor who is a veteran of the United States armed forces, the reserves or the National Guard and has resided in West Virginia continuously for the four years immediately preceding the date on which the bid is submitted; **or**,
6.  **Application is made for 3.5% vendor preference who is a veteran for the reason checked:**  
 Bidder is a resident vendor who is a veteran of the United States armed forces, the reserves or the National Guard, if, for purposes of producing or distributing the commodities or completing the project which is the subject of the vendor's bid and continuously over the entire term of the project, on average at least seventy-five percent of the vendor's employees are residents of West Virginia who have resided in the state continuously for the two immediately preceding years.
7.  **Application is made for preference as a non-resident small, women- and minority-owned business, in accordance with West Virginia Code §5A-3-59 and West Virginia Code of State Rules.**  
 Bidder has been or expects to be approved prior to contract award by the Purchasing Division as a certified small, women- and minority-owned business.

Bidder understands if the Secretary of Revenue determines that a Bidder receiving preference has failed to continue to meet the requirements for such preference, the Secretary may order the Director of Purchasing to: (a) rescind the contract or purchase order; or (b) assess a penalty against such Bidder in an amount not to exceed 5% of the bid amount and that such penalty will be paid to the contracting agency or deducted from any unpaid balance on the contract or purchase order.

By submission of this certificate, Bidder agrees to disclose any reasonably requested information to the Purchasing Division and authorizes the Department of Revenue to disclose to the Director of Purchasing appropriate information verifying that Bidder has paid the required business taxes, provided that such information does not contain the amounts of taxes paid nor any other information deemed by the Tax Commissioner to be confidential.

**Bidder hereby certifies that this certificate is true and accurate in all respects; and that if a contract is issued to Bidder and if anything contained within this certificate changes during the term of the contract, Bidder will notify the Purchasing Division in writing immediately.**

Bidder: \_\_\_\_\_ Signed: \_\_\_\_\_

Date: \_\_\_\_\_ Title: \_\_\_\_\_

\*Check any combination of preference consideration(s) indicated above, which you are entitled to receive.

STATE OF WEST VIRGINIA  
Purchasing Division

**PURCHASING AFFIDAVIT**

**CONSTRUCTION CONTRACTS:** Under W. Va. Code § 5-22-1(i), the contracting public entity shall not award a construction contract to any bidder that is known to be in default on any monetary obligation owed to the state or a political subdivision of the state, including, but not limited to, obligations related to payroll taxes, property taxes, sales and use taxes, fire service fees, or other fines or fees.

**ALL CONTRACTS:** Under W. Va. Code §5A-3-10a, no contract or renewal of any contract may be awarded by the state or any of its political subdivisions to any vendor or prospective vendor when the vendor or prospective vendor or a related party to the vendor or prospective vendor is a debtor and: (1) the debt owed is an amount greater than one thousand dollars in the aggregate; or (2) the debtor is in employer default.

**EXCEPTION:** The prohibition listed above does not apply where a vendor has contested any tax administered pursuant to chapter eleven of the W. Va. Code, workers' compensation premium, permit fee or environmental fee or assessment and the matter has not become final or where the vendor has entered into a payment plan or agreement and the vendor is not in default of any of the provisions of such plan or agreement.

**DEFINITIONS:**

**"Debt"** means any assessment, premium, penalty, fine, tax or other amount of money owed to the state or any of its political subdivisions because of a judgment, fine, permit violation, license assessment, defaulted workers' compensation premium, penalty or other assessment presently delinquent or due and required to be paid to the state or any of its political subdivisions, including any interest or additional penalties accrued thereon.

**"Employer default"** means having an outstanding balance or liability to the old fund or to the uninsured employers' fund or being in policy default, as defined in W. Va. Code § 23-2c-2, failure to maintain mandatory workers' compensation coverage, or failure to fully meet its obligations as a workers' compensation self-insured employer. An employer is not in employer default if it has entered into a repayment agreement with the Insurance Commissioner and remains in compliance with the obligations under the repayment agreement.

**"Related party"** means a party, whether an individual, corporation, partnership, association, limited liability company or any other form or business association or other entity whatsoever, related to any vendor by blood, marriage, ownership or contract through which the party has a relationship of ownership or other interest with the vendor so that the party will actually or by effect receive or control a portion of the benefit, profit or other consideration from performance of a vendor contract with the party receiving an amount that meets or exceeds five percent of the total contract amount.

**AFFIRMATION:** By signing this form, the vendor's authorized signer affirms and acknowledges under penalty of law for false swearing (*W. Va. Code §61-5-3*) that: (1) for construction contracts, the vendor is not in default on any monetary obligation owed to the state or a political subdivision of the state, and (2) for all other contracts, that neither vendor nor any related party owe a debt as defined above and that neither vendor nor any related party are in employer default as defined above, unless the debt or employer default is permitted under the exception above.

**WITNESS THE FOLLOWING SIGNATURE:**

Vendor's Name: \_\_\_\_\_

Authorized Signature: \_\_\_\_\_ Date: \_\_\_\_\_

State of \_\_\_\_\_

County of \_\_\_\_\_, to-wit:

Taken, subscribed, and sworn to before me this \_\_\_\_ day of \_\_\_\_\_, 20\_\_.

My Commission expires \_\_\_\_\_, 20\_\_.

**AFFIX SEAL HERE**

**NOTARY PUBLIC** \_\_\_\_\_



## West Virginia Ethics Commission



### Disclosure of Interested Parties to Contracts

Pursuant to *W. Va. Code* § 6D-1-2, a state agency may not enter into a contract, or a series of related contracts, that has/have an actual or estimated value of \$100,000 or more until the business entity submits to the contracting state agency a Disclosure of Interested Parties to the applicable contract. In addition, the business entity awarded a contract is obligated to submit a supplemental Disclosure of Interested Parties reflecting any new or differing interested parties to the contract within 30 days following the completion or termination of the applicable contract.

For purposes of complying with these requirements, the following definitions apply:

*"Business entity"* means any entity recognized by law through which business is conducted, including a sole proprietorship, partnership or corporation.

*"Interested party" or "Interested parties"* means:

- (1) A business entity performing work or service pursuant to, or in furtherance of, the applicable contract, including specifically sub-contractors;
- (2) the person(s) who have an ownership interest equal to or greater than 25% in the business entity performing work or service pursuant to, or in furtherance of, the applicable contract. (This subdivision does not apply to a publicly traded company); and
- (3) the person or business entity, if any, that served as a compensated broker or intermediary to actively facilitate the applicable contract or negotiated the terms of the applicable contract with the state agency. (This subdivision does not apply to persons or business entities performing legal services related to the negotiation or drafting of the applicable contract.)

*"State agency"* means a board, commission, office, department or other agency in the executive, judicial or legislative branch of state government, including publicly funded institutions of higher education: Provided, that for purposes of *W. Va. Code* § 6D-1-2, the West Virginia Investment Management Board shall not be deemed a state agency nor subject to the requirements of that provision.

The contracting business entity must complete this form and submit it to the contracting state agency prior to contract award and to complete another form within 30 days of contract completion or termination.

*This form was created by the State of West Virginia Ethics Commission, 210 Brooks Street, Suite 300, Charleston, WV 25301-1804. Telephone: (304)558-0664; fax: (304)558-2169; e-mail: [ethics@wv.gov](mailto:ethics@wv.gov); website: [www.ethics.wv.gov](http://www.ethics.wv.gov).*

# West Virginia Ethics Commission Disclosure of Interested Parties to Contracts

(Required by W. Va. Code § 6D-1-2)

Contracting Business Entity: \_\_\_\_\_ Address: \_\_\_\_\_

Authorized Agent: \_\_\_\_\_ Address: \_\_\_\_\_

Contract Number: \_\_\_\_\_ Contract Description: \_\_\_\_\_

Governmental agency awarding contract: \_\_\_\_\_

Check here if this is a Supplemental Disclosure

List the Names of Interested Parties to the contract which are known or reasonably anticipated by the contracting business entity for each category below (*attach additional pages if necessary*):

**1. Subcontractors or other entities performing work or service under the Contract**

Check here if none, otherwise list entity/individual names below.

**2. Any person or entity who owns 25% or more of contracting entity (not applicable to publicly traded entities)**

Check here if none, otherwise list entity/individual names below.

**3. Any person or entity that facilitated, or negotiated the terms of, the applicable contract (excluding legal services related to the negotiation or drafting of the applicable contract)**

Check here if none, otherwise list entity/individual names below.

Signature: \_\_\_\_\_ Date Signed: \_\_\_\_\_

### **Notary Verification**

State of \_\_\_\_\_, County of \_\_\_\_\_:

I, \_\_\_\_\_, the authorized agent of the contracting business entity listed above, being duly sworn, acknowledge that the Disclosure herein is being made under oath and under the penalty of perjury.

Taken, sworn to and subscribed before me this \_\_\_\_\_ day of \_\_\_\_\_, \_\_\_\_\_.

\_\_\_\_\_  
Notary Public's Signature

**To be completed by State Agency:**

Date Received by State Agency: \_\_\_\_\_

Date submitted to Ethics Commission: \_\_\_\_\_

Governmental agency submitting Disclosure: \_\_\_\_\_

**WV-1**  
REV. 09/18/15

New  Update

STATE OF WEST VIRGINIA - PURCHASING DIVISION

**VENDOR REGISTRATION AND DISCLOSURE STATEMENT  
AND SMALL, WOMEN-, AND MINORITY-OWNED BUSINESS  
CERTIFICATION APPLICATION**

Before a vendor is eligible to sell goods and/or services to the State of West Virginia, the *West Virginia Code* §5A-3-12 requires all vendors to have on file with the West Virginia Purchasing Division a completed Vendor Registration and Disclosure Statement. All vendors wishing to participate in the competitive bid process and receive purchase orders from the State of West Virginia exceeding \$2,500 in aggregate across all state agencies are required to complete the Vendor Registration and Disclosure Statement (WV-1 form) and pay a **\$125.00** annual fee. Payment of the annual fee includes email notifications on bid opportunities based on the commodities and services selected upon registering in the Vendor Self-Service (VSS) portal at [wvOASIS.gov](http://wvOASIS.gov). Please complete this form in its **ENTIRETY** and return it with a check or money order made payable to the **STATE OF WEST VIRGINIA** in the amount of **\$125.00**. Incomplete forms will not be processed and will be returned to the vendor. Please send completed form and payment to:

**Purchasing Division - Vendor Registration  
2019 Washington Street East  
Charleston, WV 25305-0130**

Whenever a change occurs in the information submitted, such change shall be reported immediately in the same manner as required in the original disclosure statement (*West Virginia Code* §5A-3-12). Vendors doing business with the State of West Virginia are expected to abide by the **Vendor Code of Conduct** available online at [www.state.wv.us/admin/purchase/vrc/vendorconduct.pdf](http://www.state.wv.us/admin/purchase/vrc/vendorconduct.pdf).

**Privacy Notice:** The Purchasing Division is required to collect certain information as stated in *West Virginia Code* §5A-3-12, other applicable sections of the *West Virginia Code*, the Vendor Registration and Disclosure Statement forms, and other documents to facilitate the state bidding and contract administration processes. This information is stored in a secure environment, but unless specifically protected under state law, any information provided may be inspected by or disclosed to the public.

Vendors are also required to be licensed and in good standing in accordance with any and all state and local laws and requirements by any state or local agency of West Virginia, including, but not limited to, the West Virginia Secretary of State's Office, the West Virginia Tax Department, West Virginia Insurance Commission, or other state agencies or political subdivisions. Failure to do so may result in delay of or disqualification from a contract award pursuant to *West Virginia Code of State Rules* §148-1-6.1.7.

Should you need additional information relating to vendor registration, please visit [www.state.wv.us/admin/purchase/VendorReg.html](http://www.state.wv.us/admin/purchase/VendorReg.html). Questions concerning this Vendor Registration and Disclosure Statement may be directed to the Purchasing Division at (304) 558-2311.

**VENDOR REGISTRATION AND DISCLOSURE STATEMENT AND SMALL, WOMEN-, AND MINORITY-OWNED BUSINESS CERTIFICATION APPLICATION**

PLEASE TYPE OR CLEARLY PRINT ALL INFORMATION  
To Be Completed by the Vendor and Returned to the Purchasing Division

1. Legal Name of Company/Individual \_\_\_\_\_

Bidding Address \_\_\_\_\_

Ordering Address \_\_\_\_\_

Payment Address \_\_\_\_\_

City, State, Zip \_\_\_\_\_

Telephone Number \_\_\_\_\_ Fax Number \_\_\_\_\_

Principle Contact Person \_\_\_\_\_ E-mail \_\_\_\_\_

Contact's Telephone Number \_\_\_\_\_ Contact's Fax Number \_\_\_\_\_

DBA, if any \_\_\_\_\_

Bidding Address \_\_\_\_\_

Ordering Address \_\_\_\_\_

Payment Address \_\_\_\_\_

City, State, Zip \_\_\_\_\_

Telephone Number \_\_\_\_\_ Fax Number \_\_\_\_\_

Principle Contact Person \_\_\_\_\_ E-mail \_\_\_\_\_

Contact's Telephone Number \_\_\_\_\_ Contact's Fax Number \_\_\_\_\_

2. Vendor Tax Classification:

- Individual
- Sole Proprietor
- Partnership
- Corporation
- Board Member
- Trust
- Estate

- Government
- Medical Corporation
- Attorney Corporation
- Non-Profit Organization
- Payroll
- Employee

## VENDOR REGISTRATION AND DISCLOSURE STATEMENT AND SMALL, WOMEN-, AND MINORITY-OWNED BUSINESS CERTIFICATION APPLICATION

PLEASE TYPE OR CLEARLY PRINT ALL INFORMATION  
To Be Completed by the Vendor and Returned to the Purchasing Division

**3. Taxpayer Identification Number (TIN):** If you have an Identification Number, enter it below. All partnerships, corporations, or companies with employees must have an EIN.

EIN

If you do not have a EIN, please enter Social Security number (SSN), Individual Taxpayer Identification Number (ITIN) or Adoptive Identification Number (ATIN) and check the correct below.

- (SSN , ITIN , ATIN )

#### 4. (A) *Small, Women-Owned, Minority-Owned Businesses*

**West Virginia Code** §5A-3-59 establishes a procurement certification program in West Virginia for small, women-, and minority-owned businesses. Requirements related to the certification program are provided in the **West Virginia Code of State Rules** §148-2-1 et seq. Note that this certification provides nonresident vendors preference that is equivalent to competing resident (West Virginia) vendors that have applied for resident vendor preference, in accordance with **West Virginia Code** §5A-3-37. This certification may assist resident small, women-, and minority-owned businesses when soliciting business in other states. If you are renewing your two-year SWAM business certification status, please indicate the appropriate designation below.

**Certification of Status** (Check all those which apply)

- Minority-owned Business** [1] means a business concern that is at least fifty-one percent owned by one or more minority individuals or in the case of a corporation, partnership, or limited liability company or other entity, at least fifty-one percent of the equity ownership interest in the corporation, partnership, or limited liability company or other entity is owned by one or more minority individuals and both the management and daily business operations are controlled by one or more minority individuals.
- A "minority individual" means an individual who is a citizen of the United States or a noncitizen who is in full compliance with United States immigration law and who satisfies one or more of the following definitions:
    - **African American** means a person having origins in any of the original peoples of Africa and who is regarded as such by the community of which this person claims to be a part.
    - **Asian American** means a person having origins in any of the original peoples of the Far East, Southeast Asia, the Indian subcontinent or the Pacific Islands, including, but not limited to, Japan, China, Vietnam, Samoa, Laos, Cambodia, Taiwan, Northern Mariana, the Philippines, a U.S. territory of the Pacific, India, Pakistan, Bangladesh, or Sri Lanka and who is regarded as such by the community of which this person claims to be a part.
    - **Hispanic American** means a person having origins in any of the Spanish-speaking peoples of Mexico, South or Central America, or the Caribbean Islands or other Spanish or Portuguese cultures and who is regarded as such by the community of which this person claims to be a part.
    - **Native American** means a person having origins in any of the original peoples of North America and who is regarded as such by the community of which this person claims to be a part or who is recognized by a tribal organization.

**VENDOR REGISTRATION AND DISCLOSURE STATEMENT AND SMALL, WOMEN-, AND MINORITY-OWNED BUSINESS CERTIFICATION APPLICATION**

PLEASE TYPE OR CLEARLY PRINT ALL INFORMATION  
To Be Completed by the Vendor and Returned to the Purchasing Division

- Small Business [2]** means a business, independently owned or operated by one or more persons who are citizens of the United States or noncitizens who are in full compliance with United States immigration law, which, together with affiliates, has two hundred fifty or fewer employees, or average annual gross receipts of \$10 million or less averaged over the previous three years.
- Women-owned Business [3]** means a business concern that is at least fifty-one percent owned by one or more women who are citizens of the United States or noncitizens who are in full compliance with United States immigration law, or in the case of a corporation, partnership or limited liability company or other entity, at least fifty-one percent of the equity ownership interest is owned by one or more women who are citizens of the United States or noncitizens who are in full compliance with United States immigration law, and both the management and daily business operations are controlled by one or more women who are citizens of the United States or noncitizens who are in full compliance with United States immigration law.

**(B) Other Federal Designations**

Additionally, by providing the following information, I represent that this enterprise is a small business as defined by the **Code of Federal Regulations**, Title 13, Part 121, as appended - which contains detailed industry definitions and related procedures - and/or the characteristics of the enterprise's control, operation and/or ownership are accurately reflected in the information provided. *Check all that apply.*

- Disabled Small Business Ownership [4]
- Veteran Small Business Ownership [5]

**5. Commodity Codes:** You may register for commodity codes for the products and services that you offer, which will provide you with bid opportunity alerts and notifications should you become a paid registered vendor. To perform this function, visit the Vendor Self-Service (VSS) Portal at [wvOASIS.gov](http://wvOASIS.gov).

**6. List the name, title, city and state of residence for all owners/officers.** If the vendor is an **individual**, list his or her name and city and state of residence, and, if he or she has associates or partners sharing in his or her business, list their names and city and state of residence. If the vendor is a **firm**, list the name and city and state of residence of each member, partner or associate of the firm. If the vendor is a **corporation** created under the laws of this state or authorized to do business in this state, list the names and city and state of residence of the president, vice president, secretary, treasurer and general manager, if any, of the corporation; and the names and city and state of residence of each stockholder of the corporation owning or holding at least ten percent of the capital stock thereof. Attach an additional sheet if space is needed.

Name	Position	City and State of Residence

If the vendor has only one owner/officer, list the name, position, and city and state of residence above and please initial here: \_\_\_\_\_

**VENDOR REGISTRATION AND DISCLOSURE STATEMENT AND SMALL, WOMEN-, AND MINORITY-OWNED BUSINESS CERTIFICATION APPLICATION**

PLEASE TYPE OR CLEARLY PRINT ALL INFORMATION  
To Be Completed by the Vendor and Returned to the Purchasing Division

7. List the name and telephone number of one or more banking institutions to serve as reference for the vendor.

8. What is the latest Dun & Bradstreet number and rating on the vendor? \_\_\_\_\_

9. Is the vendor acting as an agent for some other individual, firm or corporation? If yes, attach statement of the principal authorizing such representation.  No  Yes

By signing below and submitting this form, the vendor certifies and acknowledges that: 1) it has obtained all licenses, certifications, and authorizations necessary to lawfully conduct business in the state of West Virginia; and 2) that the assertions made by completing this form and delivering it to the Purchasing Division are accurate and true in accordance with the applicable law and rules. As authorized agent of the vendor named herein, I do solemnly swear that the above information is true and complete, in accordance with **West Virginia Code §5A-3-12(e)**.

In the event that the vendor is applying for certification as a small, women-, or minority-owned business, the vendor's signature below further certifies that: 1) the state in which the vendor has its headquarters or principal place of business does not deny a like certification to a West Virginia based small, women-owned, or minority-owned business; 2) the state in which the vendor has its headquarters or principal place of business does not provide a preference to small, women-owned, or minority-owned firms that is unavailable to West Virginia based businesses; and, 3) that it has read and understands this form, along with the law and rules governing certification as a small, women-owned, or minority-owned business.

\_\_\_\_\_  
*Authorized Agent of Vendor (Print Name)*

\_\_\_\_\_  
*Authorized Agent (Signature)*

\_\_\_\_\_  
*Title*

\_\_\_\_\_  
*Date*

<p><b>PURCHASING DIVISION USE ONLY</b></p> <p>Vendor ID: _____</p> <p>Check No. : _____</p> <p>Memo No. : _____</p> <p>Date: _____</p> <p>Entered by: _____</p>
---



## Submission Instructions for Suppliers

Please follow these instructions to submit via our Public Portal.

### 1. Prepare your submission materials:

#### Requested Information

Name	Type	# Files	Requirement	Instructions
Proposal	File Type: PDF (.pdf)	Multiple	Required	
Untitled BidTable (BT-69ST)	BidTable: Excel (.xlsx)	1	Required	You will need to fill out the provided Response Template for this BidTable. The Response Template can be downloaded from the project listing on the Bonfire portal.

#### Requested Documents:

Please note the type and number of files allowed. The maximum upload file size is 1000 MB. Please do not embed any documents within your uploaded files, as they will not be accessible or evaluated.

**Requested BidTables:** The BidTable Response Templates can be obtained at <https://marshall.bonfirehub.com/opportunities/7874>.

Please note that BidTables may take a significant amount of time to prepare.

### 2. Upload your submission at:

<https://marshall.bonfirehub.com/opportunities/7874>

Your submission must be uploaded, submitted, and finalized prior to the Closing Time of **Apr 26, 2018 3:00 PM EDT**. We strongly recommend that you give yourself sufficient time and **at least ONE (1) day** before Closing Time to begin the uploading process and to finalize your submission.

#### Important Notes:

Each item of Requested Information will only be visible after the Closing Time.

Uploading large documents may take significant time, depending on the size of the file(s) and your Internet connection speed.

You will receive an email confirmation receipt with a unique confirmation number once you finalize your submission.

Minimum system requirements: Internet Explorer 11, Microsoft Edge, Google Chrome, or Mozilla Firefox. Javascript must be enabled. Browser cookies must be enabled.

#### Need Help?

Marshall University uses a Bonfire portal for accepting and evaluating proposals digitally. Please contact Bonfire at [Support@GoBonfire.com](mailto:Support@GoBonfire.com) for technical questions related to your submission. You can also visit their help forum at <https://bonfirehub.zendesk.com/hc>



Primary Responses

Success: All data is valid!

Status	Bid/No Bid Decision	#	Items	Quantity Required	Numeric	Text	Text	Total Cost
					Unit Price	(Scheduled if applicable)	(Additional Text Box)	
Not Bidding	No Bid	#0-1	Speed Queen Stack Washer/Dryer Electronic Homestyle/Mod- LTEE5ASP175TW01/ 240V	4				
Not Bidding	No Bid	#0-2	Speed Queen Stack Dryer Electronic Homestyle/Mod- LSEE5AGW173TW01/ 240V	14				
Not Bidding	No Bid	#0-3	Speed Queen Front Load Washer Electronic Homestyle ADA Compliant/ MOD- LFNE5BSP115TW01	10				
Not Bidding	No Bid	#0-4	Speed Queen Single Dryer Electronic Homestyle ADA Compliant/Mod- LDE30RGS173TW01	47				
Not Bidding	No Bid	#0-5	Speed Queen 3 Prong Dryer Cord	54				
Not Bidding	No Bid	#0-6	Speed Queen 4 Prong Dryer Cord	30				
Not Bidding	No Bid	#0-9	Braded Washer Hose- Hot	78				
Not Bidding	No Bid	#0-10	Braded Washer Hose- Cold	78				

**SAMPLE**